



RINGWAY

Control & Automation

Head Office

Ringway Control & Automation
ABN 47 087 315 179
4 Lady Penrhyn Dr,
Unanderra, NSW 2526
products@ringway.com.au
Ph 02 4255 4300 Fax 02 42718990

Mackay Office

Ringway Materials Handling
Unit 10 Woodman Pde,
Mackay, QLD 4740
products@ringway.com.au
Ph 07 49524001 Fax 07 49522216



AC/DC & DC/DC

Opto-Isolators

RINGWAY OPTO-ISOLATORS

DESCRIPTION:

The Ringway ISOPLC Series of Opto-Isolators are designed to allow the isolated monitoring of low voltage AC signals (100-250V) or Extra low voltage DC (24-50V) signals using standard DC PLC inputs. The isolators work by switching their output to the PLC on while an input signal is present. The Isolator output to the PLC may be wired as either a sourcing or sinking output (refer to connection diagrams). Visual indication of the output status is provided by an LED on the front of the module, which illuminates when the output is on. The LED is wired in series with the current path of the output to the PLC which greatly reduces the possibility of false indication, a failure common to other general purpose isolators. The PLC monitoring voltage is isolated from the input via full galvanic isolation (UL1577 5000VAC, 1min.).

All modules are suitable for switching standard PLC DC voltage inputs with ratings from 12VDC to 50VDC @ 20mA.

This range of isolators are mounted in compact 60 x 58 x 20 mm DIN Rail mount enclosures.

ORDERING INFORMATION:

INPUT	PART No.
100-250V AC	ISOPLC01
24-50V DC	ISOPLC02

FEATURES:

- **Simple, robust and functional.**
- **Flexible** input voltage range.
- **Quick, easy & safe** way of monitoring AC and DC points into DC PLC inputs.
- **LED Indicator** provides visual **status** feedback.
- **LED Indicator** wired in series with output to PLC **reduces false status indication** failures modes, common to other general purpose isolators.

APPLICATIONS:

The Ringway ISOPLC Series Isolators allows for the easy connection and or monitoring of circuits with a low voltage (safe) DC PLC input. Applications include:

- Monitoring control circuit voltage into PLC for detection of control voltage failure and / or cross-interlocking of system faults.
- Retro-fit monitoring and/or control to older circuits where it is not easy or economically viable to convert to DC control.

BRIEF TECHNICAL SPECIFICATION

Type	ISOPLC01 ¹			ISOPLC02		
Nominal Input Range	100 to 250VAC			24 to 50VDC		
Output Range	12 to 50Vdc, 20mA max. (sinking or sourcing – see connection diagrams)					
Galvanic Isolation	5,000Vac for 1 minute, R.H. ≤ 60%					
Operating Temperature	-20 → +75 °C					
Output Load (PLC Input)	24V, 8mA	24V, 20mA	48V, 4.1mA	24V, 8mA	24V, 20mA	48V, 4.1mA
Min voltage for On state (design limit) ²	12.6VAC	13.9VAC	10VAC	4.3VDC	4.7VDC	3.6VDC
Typical Switch Threshold ³	11VAC	12.7VAC	9.2VAC	3VDC	3.5VDC	3VDC
Typical Output On Delay ⁴	320us	800us	520us	3.5ms	2.4ms	16.5ms
Typical Output Off Delay ⁵	20ms	21ms	26ms	20ms	20/14ms ⁶	16.5ms

Ringway ISOPLC Module wired as Sourcing output to PLC

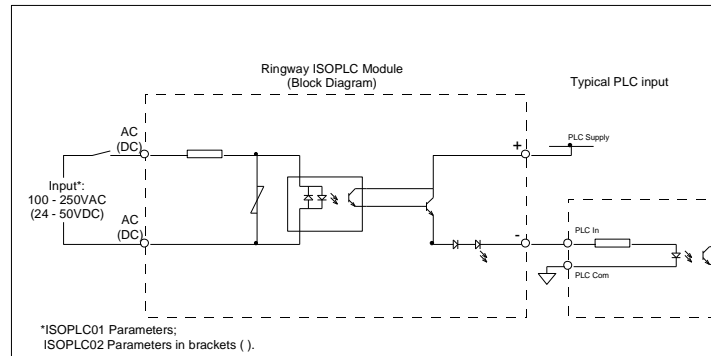

Ringway ISOPLC Module wired in Open Collector Configuration

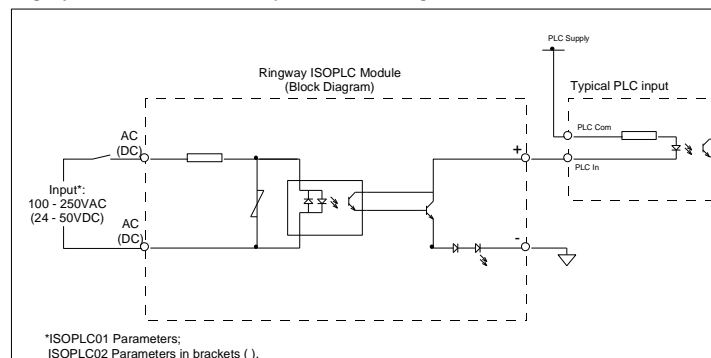

¹ All ISOPLC01 specifications at 50Hz

² Calculated minimum input voltage to ensure PLC input ON, at the nominated load @ 25°C

³ Measured device switch over threshold, at the nominated load @ 25°C

⁴ Output on delay is the time the output remains off once the input has risen above the Typical Switch Threshold voltage

⁵ Output off delay is the hold-up time (time output remains above 5V for 24V PLC input, 10V for 48V PLC input) while the input has dropped below the Typical Switch Threshold voltage

⁶ Output off delay based on 5VDC/10VDC PLC input thresholds respectively